

---

## **Application Note**

### **Using the LINK Recipe Control Function Blocks**

APP-LINK-01

## Introduction

Recipe control functions are a very powerful yet simple software tool available in the *LINK* distributed control network. There are numerous situations where the use of a recipe can simplify operating procedures on a coordinated drive system. Three basic function blocks are used in creating a recipe controller: Recipe Channel, Recipe Selector, and Recipe Handler. Additional *LINK* function blocks can be added per the individual's design choice. Before beginning to implement the software configuration, one needs to map out the recipe scheme and determine the number of different recipes and the number of "ingredients" in the recipe. (An ingredient can be any signal that will be changed in a recipe: Logic, Ordinal or Value)

## Recipe Channel

The Recipe Channel function block is the location for storing the preset values for each "ingredient" of the recipe. There are three types of Recipe Channels: Logic, Ordinal, and Value. These channels accept their respective types of signals. The function block must be opened (double click) to access the configuration data. Each time the NEW item is double clicked in the recipe channel, a new recipe preset is created. The number of presets for each recipe channel should equal the number of recipes which will be used. Each recipe channel can also be set up to have a default value on initialization.

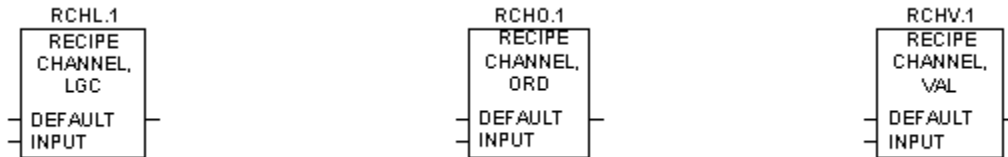

The Input of the Recipe Channel receives a signal from the source of the ingredient. This can be from a pot, ordinal counter, or logic condition. The output of the Recipe Channel is sent to the feedback component of the signal source. If there is to be no external signal coming to the Recipe Channel, the recipe presets can manually be set in the function block to operate as selectable presets.



In the example of a LINKStation Pot function block, the output of the pot would be connected to the Input of a Value Recipe Channel. The output of the Value Recipe Channel is connected to the feedback connection on the Pot. No senders should be used between the Pot and the Recipe Channel. This is because the output of the Pot and the Recipe Channel are desired to update only upon a change. This allows the Pot to function normally when operated manually. This also allows the Recipe Channel output to not be overridden by the Pot when a recipe is loaded.

## Recipe Selector

The Recipe Selector function block operates as an up-down counter with a selectable triggered output. Open the Recipe Selector function block to access the parameters which must be set up. The initial value is set to the number of the recipe which will be loaded upon initialization of the function block. The Low Limit and High Limit are set to the upper and lower boundaries of the counter. Typically, the Low Limit is set to one and the High Limit is set to the maximum number of recipes which will be used.

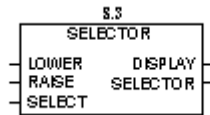

Logic signals are connected to the raise and lower of the function block to increment or decrement the counter. A logic signal for recipe Load is connected to the Select input. The function block has two outputs: Display and Selector. The Display output is connected to an Annunciator to indicate the current recipe. The Selector output is sent to the Recipe Handler function block to actually change the running recipe. The Selector function block is triggered only when the Select input is changed on a false to true transition.

## Recipe Handler

The Recipe Handler function block is the central piece of a recipe control scheme. The Recipe Handler must be loaded with each of the recipe channels that it is to control. This is done by opening the Recipe Handler function block and double clicking on the Recipe Channels item. Here is where you load each recipe channel which is desired to be controlled. The only other piece of information to be loaded is the number of the initial recipe. This recipe number will be loaded into the Recipe Handler upon initialization of the function block.

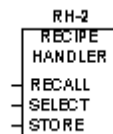

The Select output of the Recipe Selector function block is connected to the Select input of the Recipe Handler function block. Momentary logic pushbuttons (either real I/O or a touchscreen button) are connected to the Recall and Store inputs. When the Recall input sees a false to true transition, the recipe handler will load the recipe values for the number seen at the Select input. (This logic signal should be sent to the Recall input of the Recipe Handler function block and to the Select input of the Recipe Selector.) When the Store input sees a false to true transition, Each Recipe Channel stores their current values for the selected recipe. Previous recipe values for the selected recipe are lost. This function is used to change and save recipe information.

## Guidelines

Shown below is a simple diagram of a recipe control application.

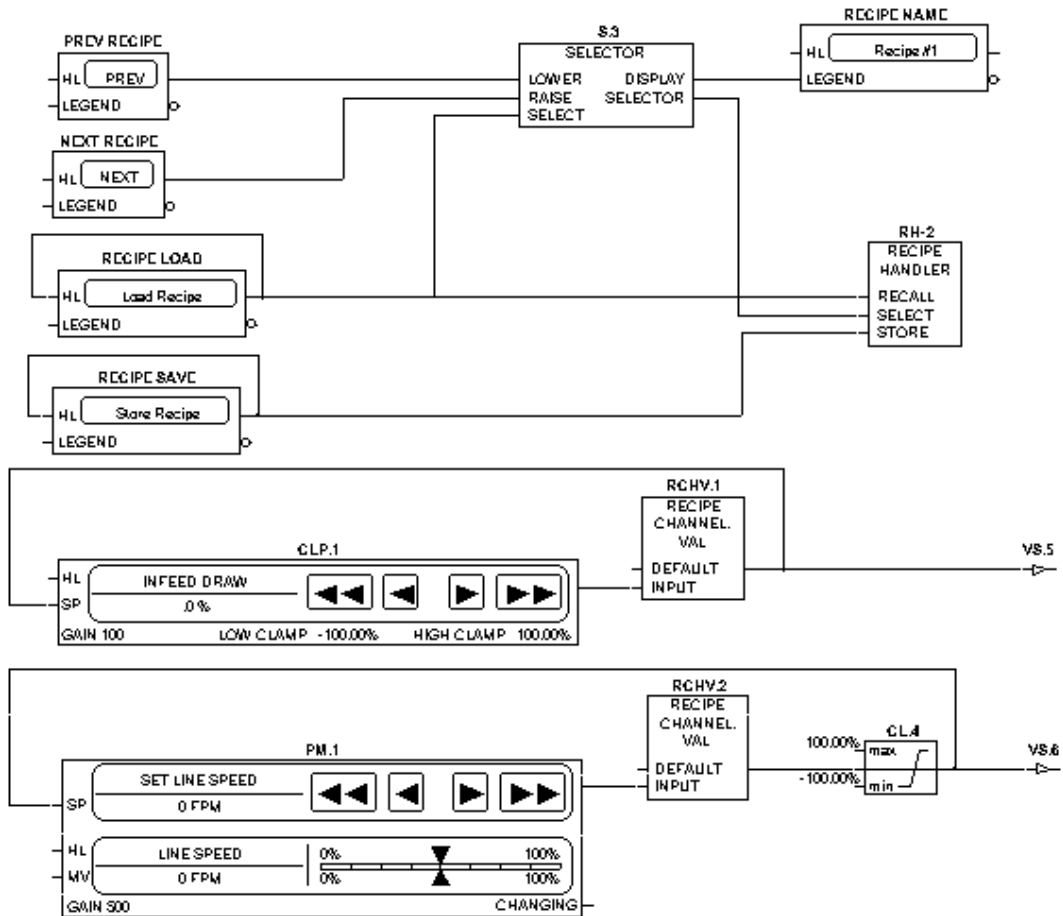

Additional help for each of the recipe control function blocks can be found under the Data Sheets section of the Help menu in Configuration Editor.