

## Objective

Provide tips for different PLC tools to be used with SSD Drives products

## Equipment

Master PLC, Communication TechBox (6053/6055) or Communication LinkCard (L53xx)

## Procedure

### FOR ALL DRIVE CONFIGURATIONS REGARDLESS OF PLC TYPE:

- Delete internal software connections to the drive parameter that will be written to by the PLC. Otherwise, the internal drive connection will overwrite the data to the specific tag number.
- The SSD Drives datasheet file formats all parameters to be transmitted and received as 16-bit words.
- Any drive parameter with a tag number can be read or write via the PLC. I/O points that attach to customer connections must be properly triggered in the 590+ drive. Any function block output under the SYSTEM::CONFIGURE I/O::BLOCK DIAGRAM that is being read by the PLC must be triggered. The examples below show how to trigger correctly. The 690+ drive does not require the function block output to be connected to a system block to be triggered.

Note: The value for Analog Input 1 is read directly at Setpoint Sum 1::Input 0. The Setpoint Sum 1 block is the trigger for Analog Input 1.

Note: The value for Analog Input 2 is read directly at the miniLink. The miniLink block is the trigger for Analog Input 2.

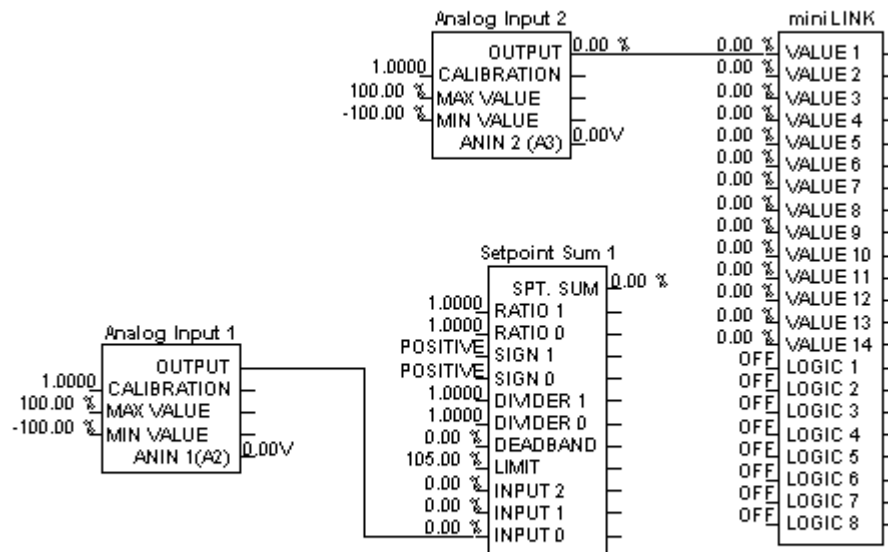

If you have questions, please call the Product Support Group at (704) 588-3246.

Communication Option	Protocol	Master	Maximum Nodes	Maximum Words per Card	Communication Speed
L5351	Device Net (CAN Bus)	Allen-Bradley PLCs	64	127 per node	125, 250, 500 Kbaud
L5352	Modbus TCP/IP Ethernet IP	Modbus TCP/IP PCs and PLCs  Ethernet IP Allen Bradley ControlLogix	256	256	10 or 100 Mbaud
L5353	Profibus	Siemens/TI PLCs	32	112	9.6, 19.2, 93.75, 187.5, 500 Kbaud, 1.5, 12 Mbaud
L5354	ControlNet	Allen-Bradley PLCs	99	240	5 Mbaud
L5355	Modbus TCP, Modbus Plus	Modicon PLCs	256	256	1 Mbaud
6055/DNET/00 6053/DNET/00	Device Net (CAN Bus)	Allen-Bradley PLCs	64	Limited by Polled Assy. Number	125, 250, 500 Kbaud
6055/MBP/00 6053/MBP/00	Modbus TCP, Modbus Plus	Modicon PLCs	256	Limited by I/O Point to Point selection	1 Mbaud
6055/CNET/00 6053/CNET/00	ControlNet	Allen-Bradley PLCs	99	Limited by I/O Point to Point selection	5 Mbaud
6055/ENET/00 6053/ENET/00	Modbus TCP/IP Ethernet IP	Modbus TCP/IP PCs and PLCs  Ethernet IP Allen Bradley ControlLogix	256	590+ 20 Read, 20 Write words  690+ 36 Read, 36 Write words	10 or 100 Mbaud
6055/PROF/00 6053/PROF/00	Profibus	Siemens/TI PLCs	32	16 Read, 16 Write words	9.6, 19.2, 93.75, 187.5, 500 Kbaud, 1.5, 12 Mbaud
6055/EI00/00 6053/EI00/00 6513/00	EI Bisynch ASCII/Binary, Modbus RTU	Any PC or PLC with EI Bisynch or Modbus RTU comms.	256	32 Read, 32 Write words	1200 to 57600 Kbaud

If you have questions, please call the Product Support Group at (704) 588-3246.