

**Purpose:**

To assist with troubleshooting a suspected network problem with a LINK fiber-optic network.

Note: The NEP (Network Exceptions Logger) is a standard L5203 Serial Module with a configuration that transmits all network exceptions to an RS-232 serial port.

**Hardware required:**

1 each	L5203-2-00	Serial I/O Module preloaded with Production/Ship configuration (Addr. 600)
1 each	CM352581	Cable Assembly, DE-9S to Terminals L5203 to PC or CM351435 Cable Assembly, DB-25P to Terminals L5203 to Printer
2 each		Fiber optic cables (4 each for redundant)
2 each		Wires for 24 VDC power supply for module
1 each		Computer with terminal emulation software or Windows installed or RS-232 serial printer

**Installation procedure:**

1. Connect 24 VDC to terminals 3 or 4 of TB1 and the 0 VDC common to terminals 1 or 2 of TB1.

Note: Preferably this supply is separate from the LINK system's 24 VDC supply. Supplying the L5203 with a separate supply allows any Network Exception to be recorded during operation of the system.

2. Install a fiber optic jumper between FO1 and FO2 on the serial module.
3. Install the 3 terminal connections of either the CM352581 (computer) or CM351435 (printer) cable to the RS-232 - Channel B.

Note: The cable terminals marked RCV, XMT, and G should be installed into terminals 9 (XMT), 10 (RCV), and 11 (CMN), respectively, on the L5203 module.

4. Apply power to the 24 VDC supply.

Note: The red LED on the L5203 should be on solid (not blinking). If the LED is blinking, verify all connections before continuing.

5. The appropriate output device must be configured to support the RS-232 port on the L5203 serial module which is set for 9600 baud, 8 data bits, no parity, 1 stop bit.

Note: If using the CM351435 printer cable with a serial printer, refer to the printer's User Manual for setup of the printer port. Usually, this is accomplished through an array of simple dip switches.

Note: If using the CM352581 computer cable, plug the connector into the serial port. Launch the terminal emulation software on your computer and set up the appropriate port on your computer to 9600, 8, N, 1.

### **Using Windows Hyper Terminal**

- A. Launch *Hyper Terminal* from the Accessories folder.
- B. Select the program *Hypertrm.exe* A *Connection Description* window will appear. In the *Name:* window enter something like *L5203 Logger*. Click *OK*.
- C. A *Connect To* window will appear. For the *Connect using* selection, select the computer comm port which will be used for the logger, probably *Direct to Com1*. Then click *OK*.
- D. A *Com Properties / Port Settings* window will appear. In this dialog box, select the following parameters and then click *OK*.

Bits per second: 9600	Stop Bits: 1
Data Bits: 8	Flow Control: XON/XOFF
Parity: None	

- E. A *L5203 Logger – Hyper Terminal* window will appear. Select the menu *Transfer / Capture Text*. A *Capture Text* Window appear. Enter the path and file name of the log file, something like *C:\L5203Log.txt* and click the *Start* button.
- F. You should now be prepared to receive data through the serial port. To test you set-up, unplug the fiber optic cable per step 6. Make sure the data is being logged.
- G. To capture the data to a file, select *Transfer / Capture Text / Stop*. If this is not done, data will not be saved to the file. You will need *WordPad* to view this file.

### **Using Windows Terminal**

- A. After starting Windows, launch the Terminal program from the Accessories folder.
- B. Under the Menu Item *Settings* select *Communications*. After selected, a set-up dialog box will appear. In this dialog box, select the following:

Baud Rate: 9600	Stop Bits: 1
Data Bits: 8	Connector: COM1 (probably)
Parity: None	Carrier Detect: None
Flow Control: XON/XOFF	

- C. Under the Menu Item *Transfer* select *Receive Text File*. After selected, a Windows dialog box will appear which will prompt you for a file name and a destination directory. Enter the path and file name of the log file, something like *C:\L5203Log.txt*
- D. After setting Terminal up in this mode, a *Stop* and *Pause* button will appear at the bottom of the screen. Unless these buttons are pressed, all network exceptions reported to the screen will be logged into the selected file. The *Stop* button will close the file from further updates while the *Pause* button will suspend recording the data to the file until logging is resumed. After pressing the *Stop* button, the log file may be printed using *WordPad*.
- E. You should now be prepared to receive data through the serial port. Go to step 6

6. Test for proper operation by unplugging the fiber optic cable from either the FO1 or FO2 connection of the L5203 module.

Note: If all connections are correct and the terminal emulation program (or printer) is set-up properly, the serial port will output the following data:

```
0d 0h 0m 31s 753ms (local) Forward Transition (both fail)
0d 0h 0m 31s 775ms (local) Fragment
0d 0h 0m 33s 210ms (local) Forward Transition (forward fail)
0d 0h 0m 33s 237ms (local) Forward Transition (both fail)
0d 0h 0m 33s 261ms addr 600 OK
0d 0h 0m 33s 286ms (local) Forward Transition (forward fail)
0d 0h 0m 33s 310ms addr 600 Network Warning
0d 0h 0m 33s 334ms addr 600 OK
```

where

**0d 0h 0m 31s 753ms (local)** is a time stamp since power was last applied to the L5203 serial module's 24 VDC power terminals (**d**ay, **h**our, **m**inute, **s**econd, **ms**illisecond)

**(local)** is the L5203 NEP Logger module itself, reporting the network exception.

**Forward Transition (forward fail)** is the network exception reported by the module

7. The L5203 NEP Logger may be placed in the LINK Network to diagnose Network problems.

Note: The user will want to place the associated machinery in a safe condition prior installing the logger. Once in the system, the logger is transparent to all other control logic which may be installed in the system.

The network topology determines how many fiber optic jumpers are required to insert the module into the network. Simply hook the module up in accordance with the network topology supplied by the system designer

8. After inserting the logger into the network, resume normal operations of the equipment while monitoring the output of the logger. Note: For printers, a hard copy of all network exceptions will be recorded. For terminal emulators, the data being received will have to be stored to a file for later printing.

## EXAMPLE

Shown Below is an example of the data, that the L5203 NEP LOGGER will generate.

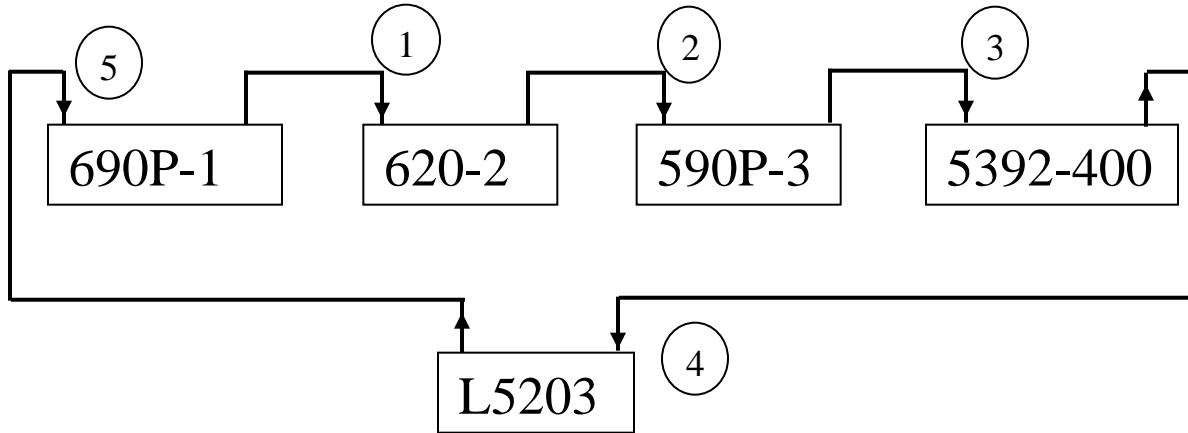

### Link Topology - Simple

The L5392-400 System Control blocks: “Restart on Network Failure”, “Restart on Module Failure” and “Restart on configuration” are set to “Disabled”. The 690P-1, 620-2 & the 590P-3 System control blocks are all set to Enabled. L5203 is address 600.

#### Power up Network:

```

0d 0h 0m 0s 43ms addr 600 OK
0d 0h 0m 0s 498ms addr 2 OK
0d 0h 0m 0s 892ms addr 3 Checking Network
0d 0h 0m 0s 915ms addr 3 Peer Halted
0d 0h 0m 0s 938ms addr 3 OK
0d 0h 0m 1s 181ms addr 400 Checking Network
0d 0h 0m 1s 219ms addr 400 Peer Halted
0d 0h 0m 1s 255ms addr 400 OK
  
```

#### REMOVE FIBER 5

```

0d 0h 2m 59s 343ms addr 1 Network Failure
0d 0h 2m 59s 367ms addr 1 Shutdown
0d 0h 2m 59s 390ms addr 3 Shutdown
0d 0h 2m 59s 413ms addr 2 Shutdown
0d 0h 2m 59s 436ms addr 3 Initialization
0d 0h 2m 59s 459ms addr 1 Initialization
0d 0h 2m 59s 863ms addr 1 Checking Network
0d 0h 2m 59s 937ms addr 3 Checking Network
  
```

### REINSTALL FIBER 5

0d 0h 4m 5s 926ms addr 1 Peer Halted  
0d 0h 4m 6s 0ms addr 3 Peer Halted  
0d 0h 4m 6s 22ms addr 3 OK  
0d 0h 4m 6s 170ms addr 2 OK  
0d 0h 4m 8s 24ms addr 1 Checking Network  
0d 0h 4m 8s 47ms addr 1 Peer Halted  
0d 0h 4m 8s 70ms addr 1 OK

### REMOVE 1 FIBER

0d 0h 5m 24s 375ms addr 2 Network Warning  
0d 0h 5m 25s 377ms addr 2 Network Failure  
0d 0h 5m 25s 401ms addr 3 Shutdown  
0d 0h 5m 25s 424ms addr 2 Shutdown  
0d 0h 5m 25s 446ms addr 3 Initialization  
0d 0h 5m 25s 953ms addr 3 Checking Network

### REINSTALL FIBER 1

0d 0h 6m 27s 820ms addr 3 Peer Halted  
0d 0h 6m 28s 797ms addr 1 Peer Halted  
0d 0h 6m 28s 820ms addr 1 OK  
0d 0h 6m 29s 775ms addr 2 OK  
0d 0h 6m 29s 919ms addr 3 Checking Network  
0d 0h 6m 29s 941ms addr 3 Peer Halted  
0d 0h 6m 29s 965ms addr 3 OK

### REMOVE FIBER 2

0d 0h 8m 1s 669ms addr 3 Network Failure  
0d 0h 8m 1s 693ms addr 3 Shutdown  
0d 0h 8m 1s 716ms addr 3 Initialization  
0d 0h 8m 2s 192ms addr 3 Checking Network

### REINSTALL FIBER 2

0d 0h 8m 49s 380ms addr 3 Peer Halted  
0d 0h 8m 49s 439ms addr 1 Peer Halted  
0d 0h 8m 49s 549ms addr 2 OK  
0d 0h 8m 51s 478ms addr 3 Checking Network  
0d 0h 8m 51s 501ms addr 3 Peer Halted  
0d 0h 8m 51s 524ms addr 3 OK  
0d 0h 8m 51s 550ms addr 1 Checking Network  
0d 0h 8m 51s 574ms addr 1 Peer Halted  
0d 0h 8m 51s 597ms addr 1 OK

REMOVE FIBER 3

0d 0h 9m 30s 811ms addr 400 Network Failure

REINSTALL FIBER 3

0d 0h 11m 23s 522ms addr 3 Peer Halted  
 0d 0h 11m 23s 583ms addr 1 Peer Halted  
 0d 0h 11m 23s 723ms addr 400 OK  
 0d 0h 11m 24s 248ms addr 400 Network Failure  
 0d 0h 11m 24s 422ms addr 400 OK  
 0d 0h 11m 24s 576ms addr 2 OK  
 0d 0h 11m 25s 621ms addr 3 Checking Network  
 0d 0h 11m 25s 644ms addr 3 Peer Halted  
 0d 0h 11m 25s 667ms addr 3 OK  
 0d 0h 11m 25s 693ms addr 1 Checking Network  
 0d 0h 11m 25s 717ms addr 1 Peer Halted  
 0d 0h 11m 25s 740ms addr 1 OK

REMOVE FIBER 4

0d 0h 12m 2s 715ms (local) Forward Transition (both fail)

REINSTALL FIBER 4

0d 0h 12m 52s 274ms (local) Forward Transition (forward fail)  
 0d 0h 12m 52s 301ms (local) Forward Transition (both fail)  
 0d 0h 12m 52s 326ms addr 600 OK  
 0d 0h 12m 52s 349ms addr 600 Network Warning  
 0d 0h 12m 52s 376ms (local) Forward Transition (forward fail)  
 0d 0h 12m 52s 399ms addr 600 OK  
 0d 0h 12m 52s 653ms addr 3 Peer Halted  
 0d 0h 12m 52s 713ms addr 1 Peer Halted  
 0d 0h 12m 52s 983ms addr 2 OK  
 0d 0h 12m 54s 751ms addr 3 Checking Network  
 0d 0h 12m 54s 774ms addr 3 Peer Halted  
 0d 0h 12m 54s 797ms addr 3 OK  
 0d 0h 12m 54s 823ms addr 1 Checking Network  
 0d 0h 12m 54s 847ms addr 1 Peer Halted  
 0d 0h 12m 54s 870ms addr 1 OK

REMOVE POWER TO 690P-1

0d 0h 17m 38s 906ms addr 2 Network Warning  
**0d 0h 17m 39s 907ms addr 2 Network Failure => => See Analysis of data, listed below**  
 0d 0h 17m 39s 931ms addr 3 Shutdown  
 0d 0h 17m 39s 954ms addr 2 Shutdown  
 0d 0h 17m 39s 976ms addr 3 Initialization  
 0d 0h 17m 40s 490ms addr 3 Checking Network

RE – APPLYPOWER TO 690P-1

```

0d 0h 19m 6s 474ms addr 3 Peer Halted
0d 0h 19m 8s 572ms addr 3 Checking Network
0d 0h 19m 8s 595ms addr 3 Peer Halted
0d 0h 19m 8s 733ms addr 1 Checking Network
0d 0h 19m 8s 756ms addr 1 Peer Halted
0d 0h 19m 8s 779ms addr 1 OK
0d 0h 19m 9s 633ms addr 2 OK
0d 0h 19m 10s 670ms addr 3 Checking Network
0d 0h 19m 10s 693ms addr 3 Peer Halted
0d 0h 19m 10s 716ms addr 3 OK

```

**Analysis of data** (see REMOVE POWER TO 690P-1, listed on previous page)**0d 0h 17m 39s 907ms addr 2 Network Failure**

0d 0h 17m 39s 907ms is a time stamp since power was last applied to the L5203 serial module's 24 VDC power terminals (**day, hour, minute, second, millisecond**)

addr 2 is the address reporting a problem

Network Failure The Link network shut down because of a problem with this module.

buffer overflow So much data is being reported to the L5203 Logger, that the buffer of this logger module overflowed. At this point, all of the data in the L5203 is lost and the Link network may go down because of a L Error occurring in this module. The "baud rate" of the L5203 can be increased to prevent this overflow.

In this example, address 2 is reporting a *Network Failure*. The Link network shut down because of a problem with this module. This indicates that address 2 is receiving bad data or there is a hardware problem with this Link module.(In this case power was removed from this module). Thus the problem can be: the **fiber optic receiver** of address 690P-1, the **fiber optic transmitter** of the module sending data to address 690P-1, the **fiber optic cable**, or the fiber optic terminations between these 2 modules.

## Appendix

### Link Module States

The SSD *LINK* system defines thirteen primary states in which a module can exist:

#### States

- 0 Initialization
- 1 Halted
- 2 Missing or Bad Configuration
- 3 Crashed
- 4 OS Error
- 5 Self-Test Failure
- 6 Shutdown
- 7 OK
- 8 Network Warning
- 9 Network Failure
- 10 Checking Network
- 11 Peer Halted
- 12 Duplicate Address Detected

#### Transitions

- A Self-test failed
- B Self-test OK, config not OK
- C Self-test OK, config OK, halt flag cleared
- D Self-test OK, config OK, halt flag set
- E Duplicate address detected
- F Network present
- G All modules ready to run
- H Exception detected inside primitive operation
- J Exception detected by program
- K Module shutdown by program
- L Power fail warning
- M Power OK
- N NCP Purge
- P NCP Stop, config not OK
- R NCP Start
- S Power OK
- T NCP Stop, config OK
- U Power off

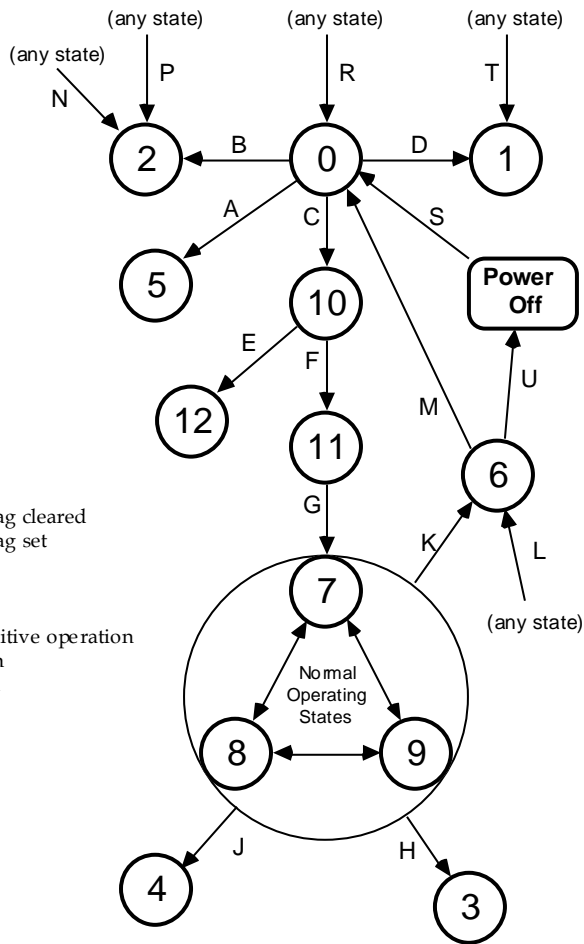

## Appendix

### **CM352581**

Cable Assembly, DE-9S to Terminals L5203 to PC layout:

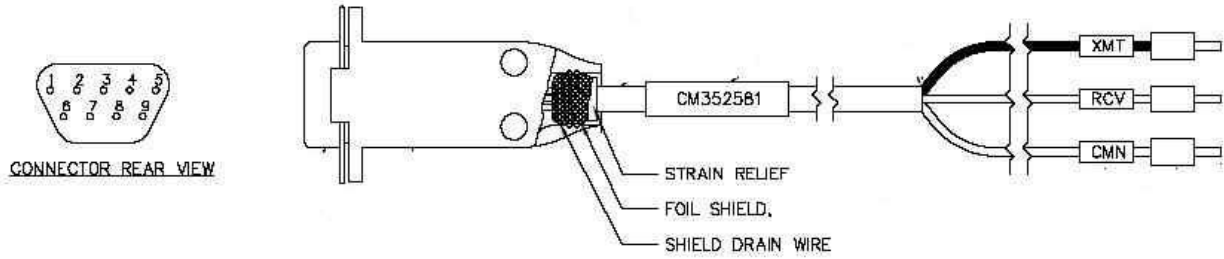

#### SCHEMATIC

