

### Objective

590 to 590+ Door Conversions.

### Equipment

Hand tools, 590+-control door (Part Number 590PXD/0011/UK/000).

### Procedure

- 1) Disconnect all power to the drive.
- 2) Determine the type of power supply board that is installed on the drive chassis to be retrofitted. The power supply board in the drive must be at or greater, then the ‘Build Standard number’ listed below, in order for the 590+ Control Door to function. If it is less, the drive can’t be converted to a 590+.

590 Series	Output Current (armature)	Power Board Part Number	Power Board Build Standard Number	Approx. Date Code
590/591 Digital/LINK	35-270A	AH385851U002, 3, 4 or 5	24 or higher	May 2005
	271-720A	AH385621U001	14 or higher	May 2005
590H/591H Digital/LINK	1200-2700A	AH466001U001	4 or higher	May 1999
590/591 598/599	35A - 2700A	Any controller with AH385128U*** power supply board.	Cannot be Retrofitted with 590PXD control door	Any Date Code

The build standard number is printed on the top right-hand corner of the power board’s bar-code label. The part number appears to the left of the build standard.

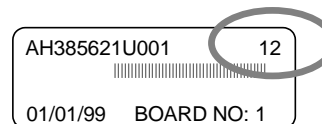

Figure -1 Example Bar Code Label

**Note: If the Build Standard for the power board is less than the above levels, the power supply board will be undersized and /or the drive armature current rating will be limited to 35 amps.**

If you have questions, please call the Product Support Group at (704) 588-3246.

## 3) Remove the old door

- a) Loosen the securing screws and open the door.
- b) Disconnect the two ribbon cable connections from the door. Also disconnect the door's earth tag at the converter.
- c) Release the hinges, as illustrated, and remove the door.

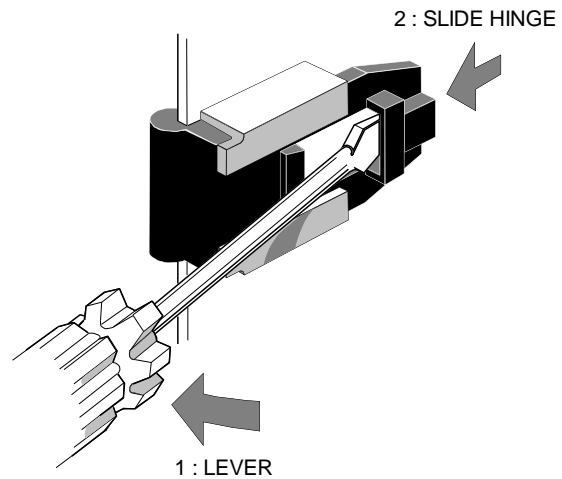

Figure -2 Hinge Release

## 4) Fitting the New Door

- a) Fit the new door by sliding the hinges into the hinge retainers until they click into place.
- b) *If fitting the new door to an existing 590 product, press out the door catch from the new door molding. The door catch may be removed and secured to the door with tape. Use the existing door screw to secure the catch to the top securing position on the converter. From now on, one screw and the door catch will secure the door. Refer to figure 3*

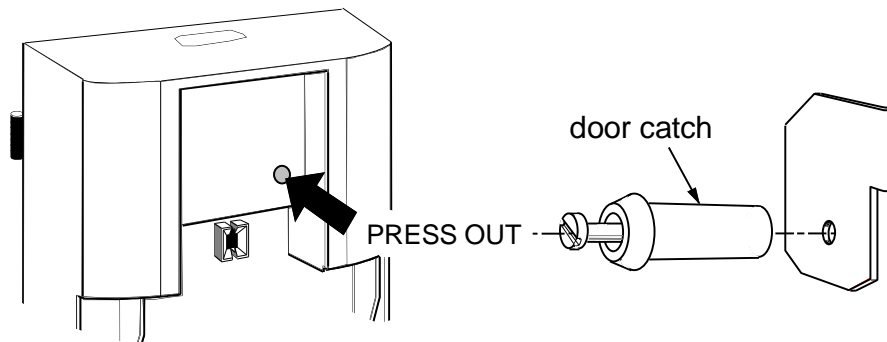

Figure -3

- c) Refit the two ribbon cable connections to the door and fit the door's earth tag to the converter.
- d) Close the door and tighten the door's securing screw(s).
- e) Electrical connections from the converter to the new door are identical to those used on the 590 doors with the added feature of an isolated motor thermal input.

If you have questions, please call the Product Support Group at (704) 588-3246.

5) Configuring the New Door

**Note:** Firmware in the control board senses the model of converter. When retrofitting an existing 590 / 590H product it will be necessary to select the correct product code. Depending on the current rating of the chassis it may also be necessary to make some hardware changes.

- a) Determine the current rating of the chassis being retrofitted.
- b) Modify the hardware as necessary. See figures 4, 5, 6 and 7 below to assist with the modification.

Output Current (armature)	Product Code (PCODE)	Hardware Modification Required
35-128A	DC Retro 4Q 128A D DC Retro 2Q 128A D	Move IA cal switch to LO position (left)
129-720A	DC Retro 4Q 720A D DC Retro 2Q 720A D	Move IA cal switch to HI position (right)
721-2700A (590 H Chassis)	Set PCODE to the amp ratings of the chassis from the drive nameplate.  Examples: DC 4Q 2700 40D DC 2Q 1200 60D	Move IA cal switch to HI position. On the power board select the armature current for 2000 amps and the field current for the drive nameplate rating.

**Figure 4**

**Note:** 590H units require the Calibration Switches on the Power Board to be set to specific positions before use.

To access the power board remove the terminal cover, unscrew the two fixings on the right hand side of the control door. Open the door to reveal the power board.

If you have questions, please call the Product Support Group at (704) 588-3246.



Figure 5

If you have questions, please call the Product Support Group at (704) 588-3246.

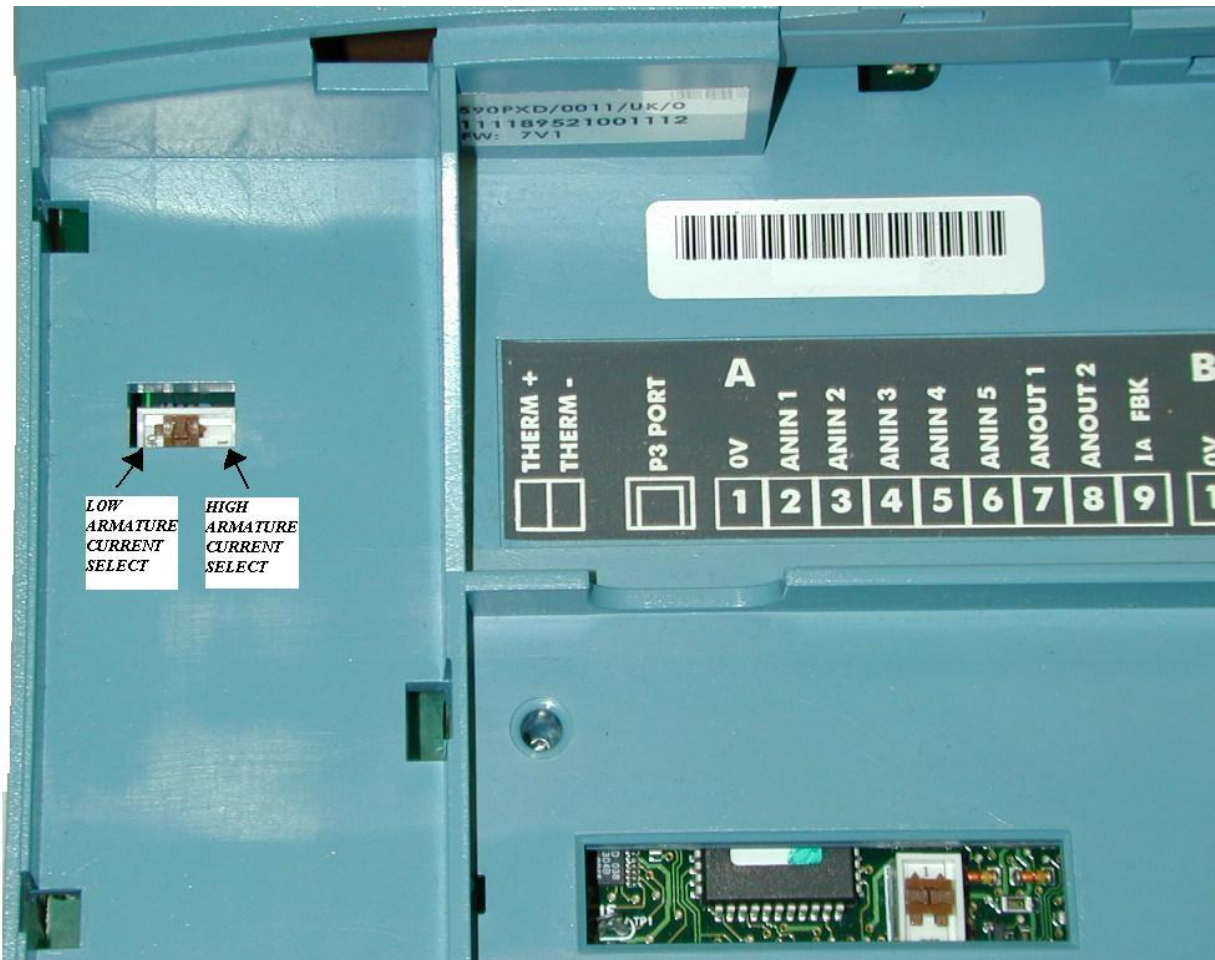

Figure 6

If you have questions, please call the Product Support Group at (704) 588-3246.

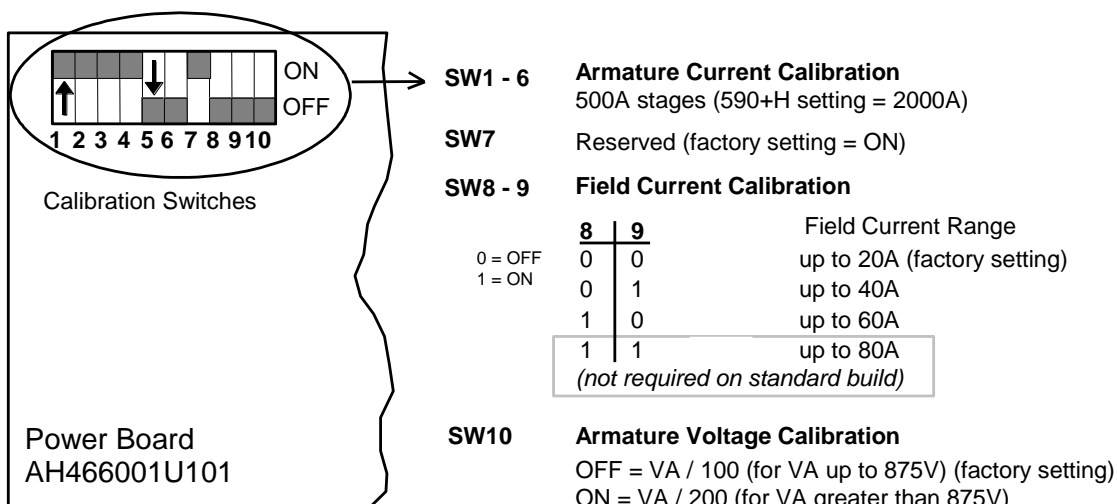

Figure 7

- 6) When the hardware changes have been completed, the product code (PCODE) needs to agree with the hardware settings. This is accomplished by doing a three button reset.
  - a) The three button reset is accomplished by holding the “UP” arrow, the “E” and the “PROG” buttons down while the control power is being applied to the drive.
  - b) The MMI will have all the lights blinking, and the LCD will read “M TO SET PCODE” “E TO SAVE PCODE”. Press the “M” button twice to start programming the PCODE. The MMI should read “PRODUCT CODE” “RETRO 4Q 720A D. The 590H will read differently on the second line, “DC 4Q 2700A 20 D”. Using the arrow buttons to adjust the PCODE to match the current rating for your chassis. The 590H/590+H needs to be set to the exact rating of the armature and field currents. Reference figure 4 for examples of the available PCODEs.
  - c) When you have selected the proper product code for your drive press the “E” button twice to exit this programming mode. The drive will go into a calibrating mode upon exiting. At this point the lights will continue blinking until the calibration is done. The MMI should read “DIGITAL DC DRIVE” and the second line should display the product code that was selected.
  - d) The 590+ has software configurable motor parameters. Program the drive with the correct motor information.

If you have questions, please call the Product Support Group at (704) 588-3246.