



Energy Savings and Payback with SSD AC890PX AC Drives

There has been quite a bit publicized on saving energy with AC Drives. If it were all true, not only would AC drives pay for themselves and save all users gobs of money on their utility bills, but it would also solve the current demand-exceeding-supply crises of our public utilities.

This note will serve to set the facts straight, de-bunk the myths, and provide practical real-world application estimates on what a user can realistically expect to get in return for their AC drive investment.



Why pumps and fans?

The main applications always cited for ROI (return-on-investment) for AC drives are centrifugal pumps and fans, for good reason. Both centrifugal pumps and fans obey what is called the *AFFINITY LAW*. The affinity law states that speed reduction results in linear flow reduction, with torque dropping off as a square of the speed reduced, and horsepower (read: *Kilowatts*) dropping off as a cube of the speed.

In theory, this means by slowing a pump or fan to 80% flow would result in nearly a 50% decrease in power consumption!* Taking it further, reducing speed and flow to 50% results in only 12.5% of the full speed power consumed.* When compared to conventional flow reduction techniques – valves for pumps, dampers or guide vanes on fans, which serve to restrict flow, the area for savings becomes apparent.

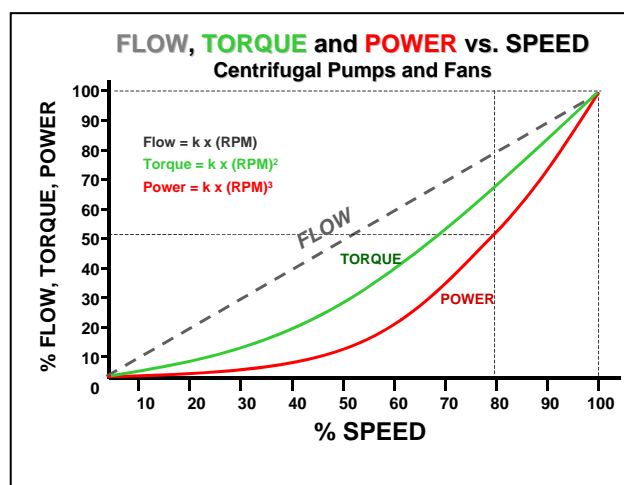

The AC drives that manufacturers target for the centrifugal pump and fan market are known as *Variable Torque Drives*. Design-wise, the power electronics are no different than *Constant Torque Drives*, other than overload ratings – typically at levels of 110% for one minute, vs. 150% on Constant Torque Drives. It's valid for the manufacturers to re-rate like this, since load drops off rapidly as speed is reduced, providing plenty of additional overload "headroom" at the new speed.

When we consider that 60% of industrial and commercial electrical consumption goes for pumps and fans, it's easy to see why drive manufacturers promote this area so heavily.

* ($0.8 \times 0.8 \times 0.8 = .512$, or 51.2% power consumed)
($0.5 \times 0.5 \times 0.5 = .125$, or 12.5% power consumed)

Have realistic expectations

The affinity curve is "theoretical" – it does not take in to account the power needed for static head pressure and "lift" (pressure created by height differential), which offsets the curve. Dynamic head pressure changes with speed, and is equivalent to frictional load losses. This means that reducing speed to reduce flow will still save energy, but not as much as the theoretical curve suggests.

Operating factors weigh heavily into power savings estimations. If a pump or fan is operating to capacity, where the installation of a drive would mean that the AC drive would always be running at 100% speed (60Hz), there will be no power saved. By introducing an AC drive, you're banking on the fact that the motor has not been designed in to full capacity – and that flow control can be implemented and exercised in the drive.

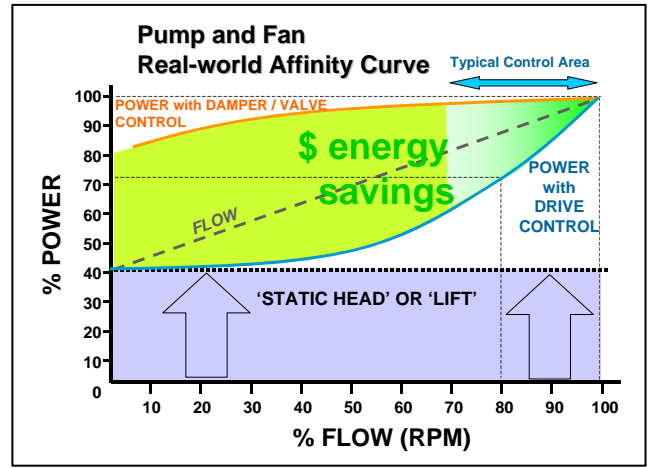
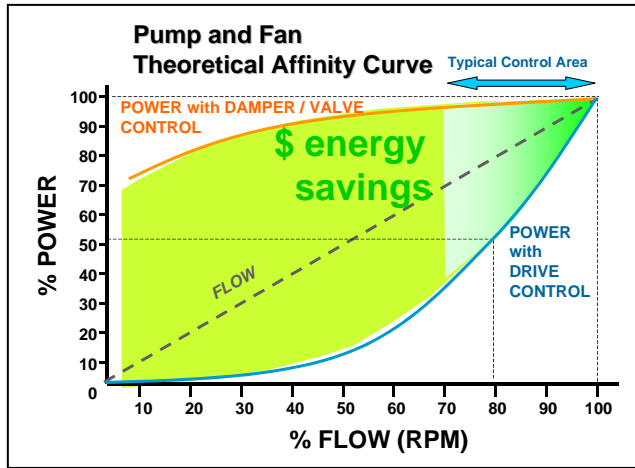

Static and dynamic backpressure caused by narrow duct runs, high loss elbows, bends and fittings are losses that have to be overcome before flow control savings are realized.

The operational duty cycle of the pump or fan will also have a direct bearing on energy savings. For obvious reasons, a pump or fan that operates 12 hours a day will impact potential energy savings proportionately. This plays an important role in payback calculations.

Real world payback

Most users want to see a payback on their AC drive investment (drive cost + installation cost) in less than 2 years for project justification. Several assumptions will be made here. First, the life cycle of the AC drive is 10 years (a conservative estimate by today's reliability standards). Second, the total installation and maintenance costs are equal to 20% of the drive's initial purchase price over this lifecycle.

The good news is that even with the most conservative estimates, energy savings alone can provide payback in a period much less than the 2-year benchmark. Putting aside the optimistic, theoretical energy savings estimates, it is reasonable to assume a conservative 20% energy savings when using an AC drive on a pump or fan application, in place of conventional flow controls. More variables will not necessarily yield greater accuracy in estimating savings. The simplest approach is to first estimate across-the-line energy consumption.

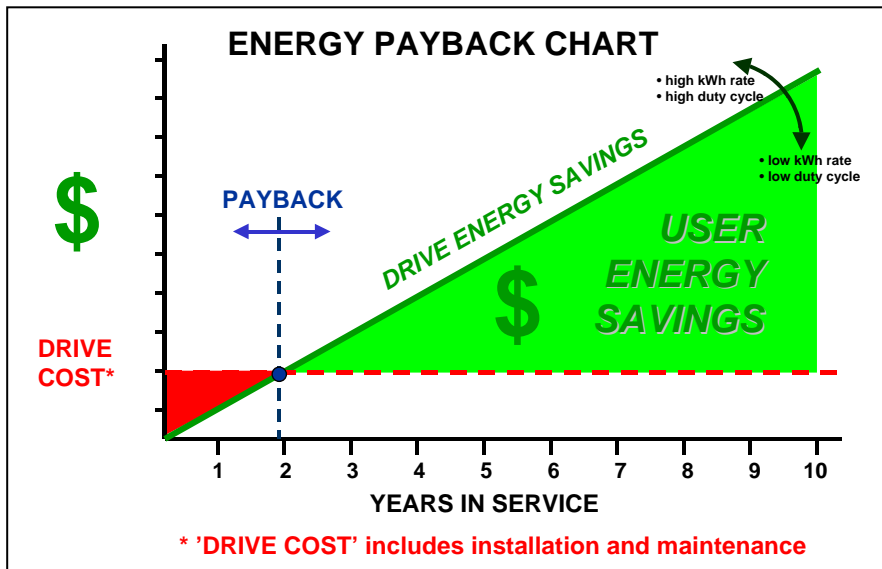

- #### PAYBACK VARIABLES
- Energy cost
 - Drive cost
 - Installation cost
 - Maintenance
 - Duty cycle of operation
 - Speed range in normal operation

Across-the-line motor operation (no drive) energy cost formula:

Annual Power Cost (\$) = (HP/motor eff.) x .746 x (\$kWh rate) x 24hrs/day x 365days/yr x (duty cycle)

AC DRIVE PAYBACK AND POWER SAVINGS (100% operational duty cycle)

HP	across-the-line (no drive) annual pwr cost	TOTAL drive expense (drive+install+maint)	AC drive annual pwr cost (@ \$.10/kWh)	AC drive annual pwr savings (@ \$.10/kWh)	AC drive payback period (years)	AC drive 10 year power savings	10 year ROI (return on investment)
100	\$72,611	\$9,600	\$58,089	\$14,522	0.66	\$145,221	1413%
200	\$143,625	\$19,200	\$114,900	\$28,725	0.67	\$287,251	1396%
300	\$213,097	\$28,800	\$170,477	\$42,619	0.68	\$426,193	1380%
400	\$284,129	\$38,400	\$227,303	\$56,826	0.68	\$568,257	1380%
500	\$351,342	\$48,000	\$281,074	\$70,268	0.68	\$702,684	1364%
600	\$421,610	\$57,600	\$337,288	\$84,322	0.68	\$843,221	1364%
700	\$491,879	\$67,200	\$393,503	\$98,376	0.68	\$983,757	1364%
800	\$562,147	\$76,800	\$449,718	\$112,429	0.68	\$1,124,294	1364%
900	\$632,415	\$86,400	\$505,932	\$126,483	0.68	\$1,264,831	1364%
1000	\$695,209	\$96,000	\$556,167	\$139,042	0.69	\$1,390,417	1348%
1100	\$764,729	\$105,600	\$611,783	\$152,946	0.69	\$1,529,459	1348%
1200	\$825,469	\$115,200	\$660,375	\$165,094	0.70	\$1,650,937	1333%
1300	\$894,258	\$124,800	\$715,406	\$178,852	0.70	\$1,788,515	1333%
1400	\$963,047	\$134,400	\$770,437	\$192,609	0.70	\$1,926,093	1333%
1500	\$1,031,836	\$144,000	\$825,469	\$206,367	0.70	\$2,063,672	1333%

AC DRIVE PAYBACK AND POWER SAVINGS (50% operational duty cycle)

HP	across-the-line (no drive) annual pwr cost	TOTAL DRIVE EXPENSE (drive+install+maint)	AC drive annual pwr cost (@ \$.10/kWh)	AC drive annual pwr savings (@ \$.10/kWh)	AC drive payback period (years)	AC drive 10 year power savings	10 year ROI (return on investment)
100	\$36,305	\$9,600	\$29,044	\$7,261	1.32	\$72,611	656%
200	\$71,813	\$19,200	\$57,450	\$14,363	1.34	\$143,625	648%
300	\$106,548	\$28,800	\$85,239	\$21,310	1.35	\$213,097	640%
400	\$142,064	\$38,400	\$113,651	\$28,413	1.35	\$284,129	640%
500	\$175,671	\$48,000	\$140,537	\$35,134	1.37	\$351,342	632%
600	\$210,805	\$57,600	\$168,644	\$42,161	1.37	\$421,610	632%
700	\$245,939	\$67,200	\$196,751	\$49,188	1.37	\$491,879	632%
800	\$281,074	\$76,800	\$224,859	\$56,215	1.37	\$562,147	632%
900	\$316,208	\$86,400	\$252,966	\$63,242	1.37	\$632,415	632%
1000	\$347,604	\$96,000	\$278,083	\$69,521	1.38	\$695,209	624%
1100	\$382,365	\$105,600	\$305,892	\$76,473	1.38	\$764,729	624%
1200	\$412,734	\$115,200	\$330,187	\$82,547	1.40	\$825,469	617%
1300	\$447,129	\$124,800	\$357,703	\$89,426	1.40	\$894,258	617%
1400	\$481,523	\$134,400	\$385,219	\$96,305	1.40	\$963,047	617%
1500	\$515,918	\$144,000	\$412,734	\$103,184	1.40	\$1,031,836	617%

1. Tables assume a 20% energy savings with AC Drive
2. DRIVE EXPENSE is based on a rate of \$80/Hp, with 20% added for installation and maintenance; actual costs will vary
3. Electricity cost is based on \$0.10 / kWh ; other rates will vary amounts proportionately
4. 'Duty Cycle' is the motor operational time ratio to total time
5. ROI is calculated by subtracting drive expense from 10-year savings, and is shown as a percentage of drive expense.

Using the table

To calculate payback, the drive purchase price and installation costs are totaled and divided by the annual savings. Annual energy savings are based on a 100% duty cycle, at a rate of \$0.10 / kWh. Adjust this amount by multiplying by the actual duty cycle. For example, if the duty cycle is just 8 hours per day, the savings will be 33% of the totals on the "100%" table, and the payback will be three times longer.

Utility rates will also change payback time in direct proportion to the rate. The rate chosen for the example, \$0.10 /per kWh, should be adjusted against the user's actual kWh rate, which may vary anywhere from \$0.04 to \$0.20, depending upon the region of the country and utility company.

Reduce Peak Demand Charges

Another area where utilities may gouge customers is with *PEAK DEMAND* charges, a surcharge based on the highest peak power measured within a predetermined timeframe. Inrush currents when starting motors across the line (no drive) are typically 6 to 7 times the motor's full load amperage rating, and remain high until the motor has reached speed. With small motors, it is doubtful inrush current will reach levels high enough for these charges to kick in. However, on larger motors that are line-started, the likelihood of hitting peak demand levels is much greater, as not only are currents are higher, but also the time needed to attain speed is longer.

There are two ways to address high inrush current – either with an electronic “soft start” panel, or with an AC drive. Electronic soft start panels limit current by reducing (phasing back) voltage with SCR switches. An effective method, but frequency is not controlled and torque is severely limited due the reduced voltage, which can pose a challenge when accelerating large fans which have a great deal of inertia.

When an AC drive is used, not only is current limited, but full load torque -with overload- is available throughout the speed range, for difficult to accelerate loads. The AC drive is a “soft-start”, only much better. Acceleration and deceleration ramp rates can be linearly controlled, and s-curve ramps are available, eliminating jerk that can occur as the ramps begin and end. This results in increased belt life, eliminates water hammer on pumps, and reduces overall wear to all mechanical components.

Improve Power Factor

Yet another area that utilities will penalize customers is poor power factor. AC induction motors running across the line have a lagging power factor (current lagging voltage). Power factor on AC motors typically range from 0.75 to 0.90. Poor power factor makes it necessary to oversize distribution system elements, to handle the extra reactive currents that do no useful work. Industrial plants deal with power factor by installing large banks of power factor correction capacitors upstream of the contributing equipment, that are switched in and out as needed to compensate for the variation in lag.

AC drives inherently correct power factor. Although the drive output to the motor may be operating at a power factor of 0.80 at a given point of time, input PF to the drive is maintained near unity (actually 0.96). Input current remains in phase with voltage, as the diodes conduct only at the peak, or center, of the sine wave. Reactive currents that flow between the motor and the drive are never seen on the drive's input.

Power factor correction capacitor banks and their associated switchgear are not needed when using AC drives –a major expense savings.

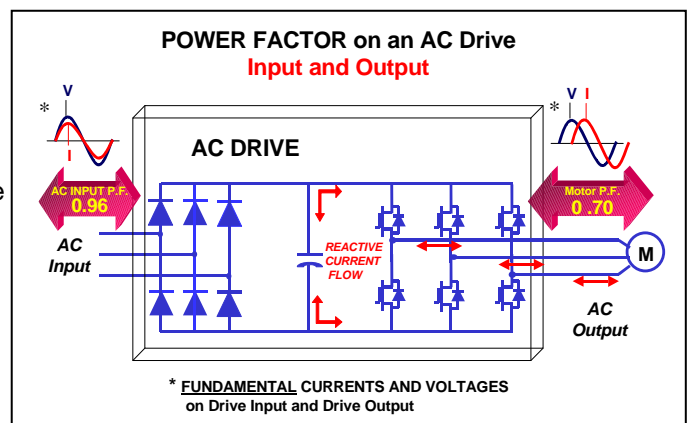

Optimize Motor Performance at light loads

Beyond this inherent PF correcting capability, the AC Drive has the intelligence to cut losses even further. It can sense when the motor is lightly loaded, and automatically reduce voltage to improve power factor in the motor. This reduces losses created by reactive circulating currents between the drive and motor. Even when running full speed, if the motor was “oversized”, the resulting current reduction means less losses in motor cabling, motor rotor and stator resistive losses.

AC Drive controller efficiency

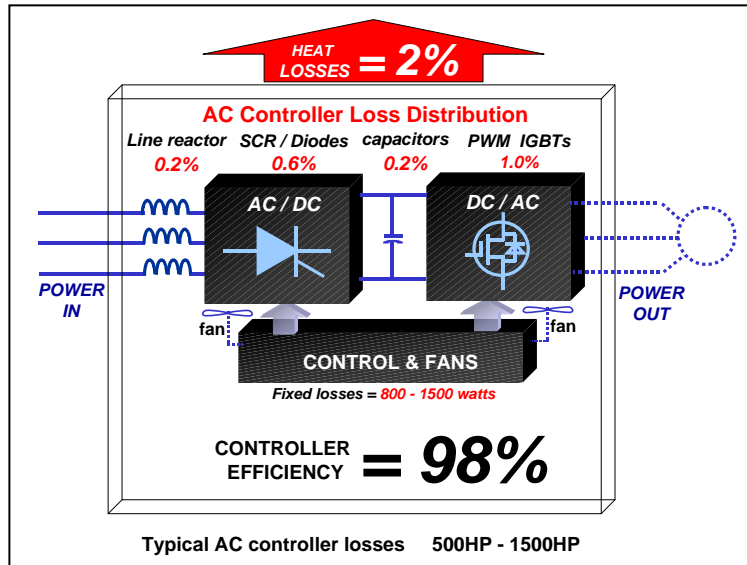

AC CONTROLLER KEY LOSS AREAS

- Power Semiconductors
- Line Reactors
- Bus Filter Capacitors
- Power supplies
- Control boards
- Cooling fans

An AC Drive controller is an electronic power converter/filter/inverter network that utilizes high-efficiency power semiconductor switches to synthesize variable frequency sine-wave power to the motor. The technique is known as PWM (pulse-width-modulation); and today's power switches are IGBTs (insulated gate bi-polar transistors).

Although this conversion process is extremely efficient, some losses still do exist and should be taken into consideration. At ratings 100HP and above, overall drive controller efficiency (ratio of electrical power out to electrical power in) is in the 98% range, at full load. This is a combination of fixed and variable losses in the controller. Fixed losses represent components such as control power supplies and heatsink cooling fans. Variable losses, which vary based on current demand, include power semiconductors in the converter and inverter sections, and the filter capacitor bank.

At a glance, 2% losses may not seem like much, but at 1000HP this translates to 20HP, or 14,920 watts loss. These losses are manifested as controller heat, which typically is forced-air ventilated from the controller cabinet. If additional cooling (such as cabinet or control room air conditioning) is required, their power consumption must also be taken into consideration.

A common misconception that exists is that an input line reactor (choke) contributes heavily to electrical losses. A 3% impedance reactor – the size most commonly recommended for harmonic control - typically adds no more than 0.2% to total controller losses. Likewise, if output reactors are used, the losses are equally low. Reactors are both cost-effective and beneficial in treatment of input line harmonics.

Drive-related motor losses

What additional losses do AC controllers introduce to induction motors? Induction motors have been designed for optimum performance on sine wave power. The content of the output of the 890PX AC controller is a PWM (pulse-width-modulated) voltage approximation of sine wave, resulting in near-sine wave currents to the motor, which acts like a large inductor. The PWM technique relies on a carrier (switching) frequency, typically in the range of 2.5 to 8 kHz. Voltage pulses are "clocked" out to the motor at this rate, which can create high-order output harmonics. The 890PX has standard output reactors, used primarily for load balancing, that also serve to reduce current harmonics and reduce harmful effects of sharp voltage pulse edges that can stress motor insulation.

Estimates of the additional motor heating effects due to these output harmonics are in the 3-5% range. However, these losses are offset by the dramatic roll-off of motor load as speed is reduced, coupled with the drive's ability to reduce motor voltage in light load situations, keeping motor efficiency near its peak level. *Any increases in motor losses from the drive are negligible in energy savings calculations!*

So where are the big pumps and fans?

Commercial HVAC represents a large market for both large (greater than 100HP) and small AC drives. Supply fans and chilled water pumps are the key applications. On the municipal front, clean water and wastewater or sludge pumps are a large chunk of the market. In the industrial sector, blowers, ID (induced draft) fans and FD (forced draft) furnace fans, as well as large centrifugal pumps can benefit by using AC drives.

Conclusion

When a user asks "How can I justifiably afford to buy a drive?" to put on a centrifugal pump or fan application, in almost every case the answer should be, "You can't afford not to!" with plenty of supporting proof. With demonstrable paybacks in 2 years or less, every dollar saved beyond that point is money in the bank. The larger the drive, the bigger the returns- a 1500 HP drive can save millions over its life cycle.

Today's smart drives do more than just control speed - they optimize power. Motor operational parameters automatically adjust at light loads, even at full speed. If a motor was "oversized" for its load - worst case for motor efficiency and power factor - the AC drive will compensate, optimizing voltage and boosting power factor.

The AC890PX is available through a worldwide network of Parker SSD Distributors and Systems Integrators.

Contact us for more information

Parker Hannifin
SSD Drives Division
9225 Forsyth Park Dr.
Charlotte, NC 28273

Tel: (704) 588-3246
Fax: (704) 588-3249

E-Mail info.us.ssd@parker.com
Website: www.SSDDrives.com

SSD Drives is a division of Parker Hannifin. With annual sales exceeding \$10 billion, Parker Hannifin is the world's leading diversified manufacturer of motion and control technologies and systems, providing precision-engineered solutions for a wide variety of commercial, mobile, industrial and aerospace markets. The company employs more than 57,000 people in 43 countries around the world. Parker has increased its annual dividends paid to shareholders for 51 consecutive years, among the top five longest-running dividend-increase records in the S&P 500 index. For more information, visit the company's web site at <http://www.parker.com>, or its investor information site at <http://www.phstock.com>.

Top Economic Reasons for using the AC890PX

- Typical paybacks in 2 years or less
- Returns 6 to 14 times its cost in energy savings over lifetime in service
- Eliminates high inrush currents and peak demand charges
- Soft-starting saves on wear-and-tear of mechanical components
- Eliminates need for power factor correction capacitors and switchgear
- Replaces inlet guide vanes and outlet dampers on centrifugal fans
- Replaces flow control valves on pumps
- Optimizes power and motor efficiency at all load levels
- Precise, reliable flow and pressure control
- Built-in input line reactors provide harmonic mitigation
- Plug and Play Modularity reduces R and D time and increases serviceability
 - Huge reduction in costs due to process line down time
 - Non-technical personnel can service the unit, by virtue of plug-and-play modules and optional 6911 HMI “cloning tool”
 - No more expensive out of town service trips by high paid/skilled engineers
- Reduced shipping cost: Small lightweight modules can be shipped anywhere in the world via UPS, Fed Ex, DHL overnight
- Ergonomically Safe: Modules weigh less than 50 pounds (23 kg) and can be handled and installed by one person with no special tools required
- Reduced inventory costs: Modules can be inventoried vs. complete drives
- Small footprint increases valuable factory floor space
- IP54 rating reduces drive killing contaminants
- Built-in dynamic braking switch AND resistor: Quick stop, full torque braking, line transient suppression
- Reduced installation costs: Fuses, line reactor, and AC disconnect are provided pre-wired to drive module
- Low Voltage control transformer increases reliability: The SMPS is isolated from the drive’s high voltage DC bus, making it less susceptible to line transients and high flywheel voltages. This allows the same tried and true SMPS design to be used even with higher line voltages (e.g. 690V)